



HORSEBOX

THE NEW HB403, HB506 & HB511

IN SAFE HANDS

SPECIALISTS IN TRAILER DESIGN & ENGINEERING

For 50 years, people have put their trust in our trailers, just ask an owner - they're not difficult to find. As specialists in trailer design and engineering, we have continued to set the standard both in the UK and throughout much of Europe. We are an independent company with one focus: to build the best products on the market. More than 30,000 people choose our trailers each year - but we're not standing still. Our dedicated investment in new technologies and materials ensures that our products continue to exceed the expectations of our customers. We know that quality, strength, value and ease of maintenance are of vital importance to you. That's why we've made them the driving force behind everything we do.



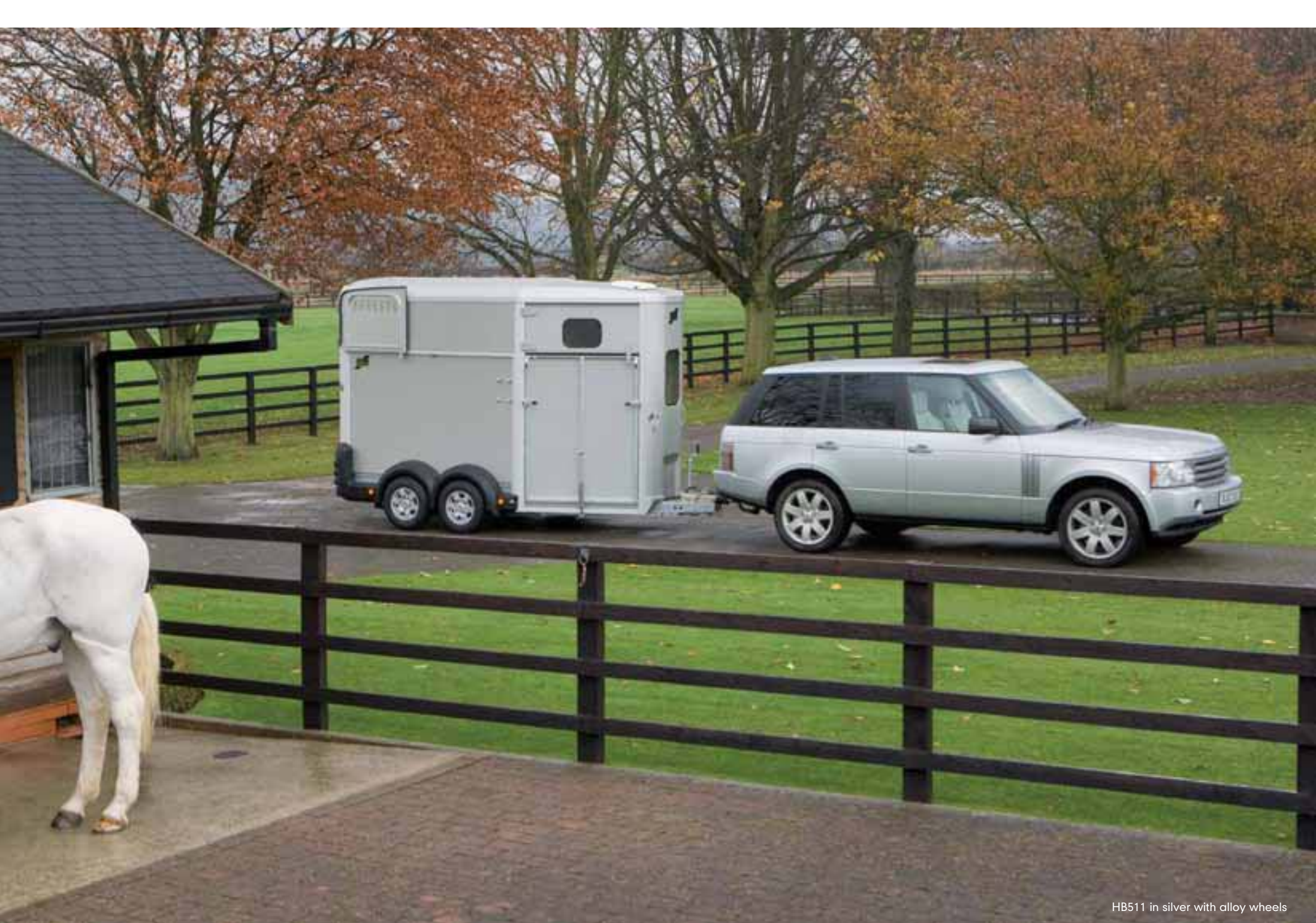

HB511 in silver with alloy wheels

TRAILER RANGE

HORSEBOX EVOLUTION

Our new range combines all the much loved qualities which have made our horseboxes so popular with a host of improvements and new features.

The exteriors have been completely re-engineered to give a striking overall appearance which will complement most 4x4 vehicles on the road today. But the beauty of our new range is not just skin deep, the comfort and safety of your horses has always been our main consideration in the re-design of the new range.

Each trailer has undergone rigorous testing, at our own facilities as well as at independent automotive testing tracks. There are three models to choose from, all available with front offload ramp and a grooms door fitted as standard.

HB506 and HB511 Double Horsebox Models.

Both models are suitable for two horses. The HB506 can accommodate two horses up to 16.2hh, the HB511 is slightly longer, wider and will carry

two 17.2hh horses. Both models feature a pair of side windows, the double horseboxes also now have a larger front inspection window which allows more daylight into the trailer. Centre partitions and breast and breeching bars are fitted as standard.

HB403 Single Horsebox. As a single horsebox, the HB403 provides more stall width than our double horsebox models and offers enough headroom to take one 16.2hh horse.

Being a narrower trailer, the HB403 is easier to tow and produces less wind resistance when towing. The HB403 is ideal for transporting nervous horses that require a wider stall and may prefer to travel alone.

A 4x4 may not be necessary to tow the HB403 (depending on vehicle's towing capacity) and also provides towing options for drivers without the B+E category on their driving licence.



HB511 in silver with alloy wheels



HB403 in graphite with sliding windows and wheel trims



HB506 in black with wheel trims and door mounted tack pack



TRAILER FEATURES

COMBINING STRENGTH, STABILITY AND STYLE

How can we improve strength and stability on an already strong and stable product whilst at the same time, focus on style? This was our design team's brief, and they succeeded.

The traditional Ifor Williams Horsebox has stood the test of time, but as car designs evolve, it is now appropriate for the horsebox to follow suit.

Using the latest manufacturing processes and techniques, our designers have improved strength throughout the trailer, from the floor to the roof. Subtle changes are combined to create an overall improved trailer.

The lockable grooms door is now wider for improved accessibility and you can also now choose which side of the trailer to position the front ramp.



DOOR CATCHES

Quick release door catches. These can be latched in both the open and closed position.



CENTRE PARTITION AND INTERIOR

A cream padding provides a light and bright interior. Hardwearing plastic kickboards along trailer sides and rubber skirts along the centre partition provide additional protection for the horse and trailer.



SIDE MARKER LIGHTS

Redesigned to complement the new lighting cluster (Fitted to HB511 only).



ALUMINIUM FLOOR & RUBBER MATTING

Our aluminium floors, fitted as standard are even stronger. Floors are covered with a 12mm thick rubber matting, providing a non-slip surface and excellent vibration absorption.





HB511 in silver with alloy wheels, storage net and camera



ROOF & VENTILATION

Smooth glass fibre roof with larger ventilation area for increased air circulation and natural light (Except for HB403, where roof vent is solid colour).



INTERIOR LIGHT

Useful on dark evenings, when loading and unloading horses.



INTERNAL DOOR LOCK

A tough nylon moulded, door latch mechanism with a smooth finish to prevent injury to horses. Can be locked and unlocked from inside the trailer.



BREAST BAR RELEASE SYSTEM

Enables the release of breast bars safely from outside of the trailer. Conveniently suits the wheel brace supplied with each horsebox.

FEATURES

Composite aluminium side panels provide a large surface area for applying graphics or decals to your trailer.

Improved trailer aesthetics include brushed aluminium frame extrusions and a lowered aluminium skirt running around the front of the trailer chassis, improving the visual appearance of the trailer.

GAS STRUT REAR RAMP

Rear ramp is now gas strut assisted, making light work of opening and closing the ramp without compromising on strength.



REAR POSITIONED SPARE WHEEL

Now positioned at the rear of the trailer, keeping side panels clear for your choice of graphics.



CLIP-ON NUMBER PLATE HOLDER

Enables you to attach your number plate to the trailer without adhesive. Number plates can be changed quickly and easily when using different towing vehicles.



MOULDED MUDGUARDS WITH INTEGRAL LIGHTS

Moulded, wrap around mudguards, incorporating trailer light cluster and reflectors.



Vanity Mirror, included as standard with all trailer models. Owners can choose where to position the mirror within the trailer.



HB506 in black with wheel trims and prop stands

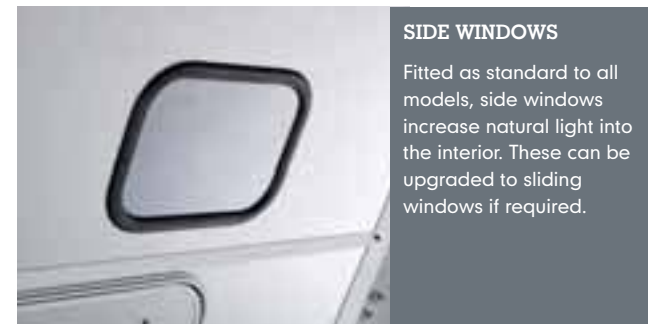

SIDE WINDOWS

Fitted as standard to all models, side windows increase natural light into the interior. These can be upgraded to sliding windows if required.



LARGER FRONT WINDOW

Fitted to double horsebox models, front windows are now larger and positioned lower to be in line with most 4x4 rear windows so that horses can be viewed from the towing vehicle.



CO-ORDINATED HANDLES

Tough nylon moulded pull handles and catches for increased strength and ease of use.

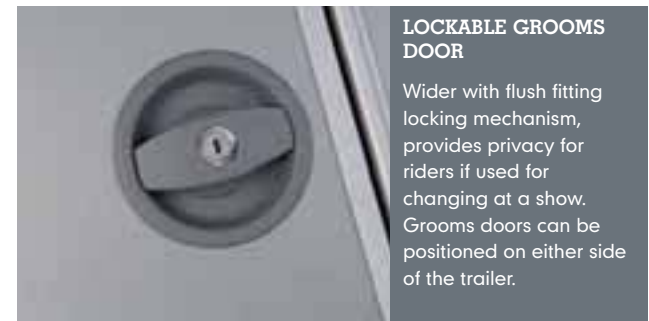

LOCKABLE GROOMS DOOR

Wider with flush fitting locking mechanism, provides privacy for riders if used for changing at a show. Grooms doors can be positioned on either side of the trailer.

RAMP OPTIONS

FRONT OFFLOAD RAMP – LEFT OR RIGHT, THE CHOICE IS YOURS

Traditionally positioned on the right side of the horsebox, customers can now choose which side the front offload ramp is positioned. Grooms doors are fitted to the opposite side chosen for the ramp.

Some may prefer the front offload ramp to be on the left so that horses can offload into the verge when out hunting. Others may prefer the

grooms door to be on the verge side so that horses can be checked during a journey without having to stand in the road.

Your distributor will be happy to discuss your requirements and recommend which side will be most appropriate for your needs.



HB506 in red with left side front offload ramp, sliding windows and wheel trims



Left front offload ramp



Right front offload ramp



REAR RAMP / VAN STYLE DOORS

For horsebox owners looking for additional versatility, choosing a rear ramp combined with van doors is ideal.

Operating as a standard ramp when loading horses, the ramp can also be opened as van doors enabling a fork lift truck to load heavy items into the trailer.

With the centre partition removed, the trailer loading area can be further increased.



HB511 in silver with alloy wheels

ACCESSORIES

FINISHING TOUCHES

Add some finishing touches to your trailer with our wide range of additional accessories, many of which are exclusive to Ifor Williams Trailers. From tack packs to trailer cameras, our accessory options make perfect additions to your trailer and if not factory fitted items, are ideal gifts for trailer owners.

Please check with your distributor before you purchase if optional accessories are a factory fit item or if they can be fitted by your distributor.



HB506 in black with wheel trims



SLIDING WINDOWS

Increase airflow with sliding windows in place of standard side windows. Window protection bars are also available.



FULL WIDTH BREAST & BREECHING BAR

For horses that prefer single travel in a wider stall. Centre partitions are removed and full width breast and breeching bars are fitted.



HORSE & TRAILER CAMERA

Wireless camera system - transmits live colour footage from the trailer interior to the towing vehicle, enables passengers to monitor the horse during transit. Can be powered from a battery pack or trailer lighting system. Supplied loose, requires fitting.



WHEEL CHOCKS

Recommended for use when uncoupling, parking and in place of the handbrake when storing your horsebox for a length of time.



TRAILER COVER

Protect your trailer from the elements with a coated nylon trailer cover. Also available in green.



HEAD PARTITION

Head partitions are easily fitted by clipping to the front panel of the trailer and the centre partition (additional fitting bar required).



STOWAGE NET

Ideal for storing trailer manuals and other small items such as hair brushes etc.



HIGH LEVEL REAR BRAKE LIGHT

Fitted to the rear roof arch, this optional brake light provides additional warning that the trailer and vehicle are braking.



FLEECE TRAVEL RUG

Keep your horse warm in winter and cool in summer when travelling with this breathable polar fleece travel rug.



TRAVEL BOOTS

A set of four, hard wearing fabric travel boots with nylon lining and padding. Provides fore and hind limb impact protection for the horse.



WHEEL TRIMS

Add the finishing touches to our standard steel wheels, by fitting a set of wheel trims (four per trailer).



ALLOY WHEELS

Give your trailer the wow factor by adding a set of exclusive alloy wheels with lfor Williams Trailers branded centres (four per trailer).



PROP STANDS

Consider prop stands if your horse requires a particularly steady surface to load. Additional support will reassure nervous horses.



TAILGUARD

Easily fitted tailguard. Protects the tail and dock whilst the horse is in transit.



SADDLE CARRIER

Protect your saddle from knocks and scrapes with this nylon padded saddle carrier.



BRIDLE BAG

Keep your bridle clean, tidy in this must have bridle bag.



HORSE & RIDER FIRST AID KIT

Contains all the essential First Aid items for the Horse and Rider.



TRAILER AID™

Use it once and you'll never be without it. Used when replacing a flat or punctured tyre. Saves time and energy, no need to use a jack.



TACK PACK – FIXED

Attached to the grooms door, this neat storage solution is capable of storing two saddles and various tack. Available in cream. Suitable for general purpose saddles up to 17" (43cm). We advise that you check saddles fit before tack pack is purchased.



TACK PACK – WHEELED

Fits neatly into the nose area of the trailer, and can be wheeled down the front ramp to empty and load (does not fit into HB403). Available in silver. Suitable for general purpose saddles up to 18" (46cm). We advise that you check saddles fit before tack pack is purchased.



TRAILER GRAPHICS

LARGE HORSE GRAPHIC
Large horse graphic set in lfor Williams logo. Suitable for HB403, HB506 and HB511 horsebox models. Graphics are supplied with fitting instructions and graphic applicator.



GALLOPING HORSE GRAPHIC

Galloping horse graphic illustrating the stages of gallop. Available in silver or black. Graphics are supplied with fitting instructions and graphic applicator.

SPECIFICATIONS

Choose from five colour options, all with colour co-ordinated rear top doors. Colours have been carefully selected to complement the colours of popular towing vehicles.



Black



Silver



Graphite



Blue



Red

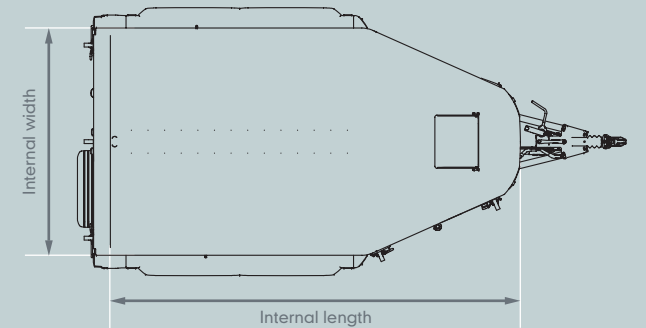
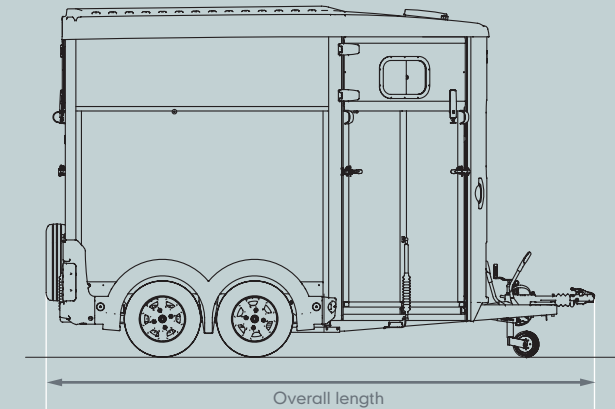
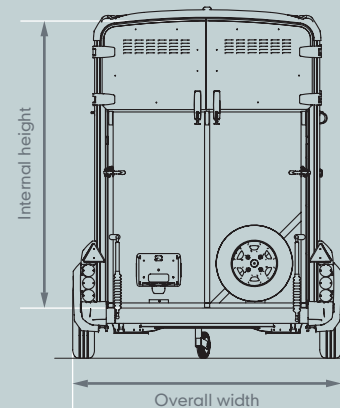
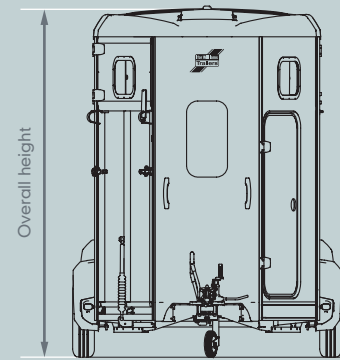

	HB403	HB506	HB511
Tyres	155R13C	165R13C	165R13C
Maximum gross weight	1600kg	2600kg	2700kg
Unladen weight	767kg	920kg	1000kg
Overall height	2.70m	2.75m	2.75m
Overall width	1.73m	2.10m	2.22m
Overall length	4.36m	4.30m	4.65m
Internal height	2.20m	2.26m	2.26m
Internal width	1.30m	1.67m	1.79m
Internal length	3.08m	3.16m	3.52m
Stall width	1.30m	0.83m	0.89m
Stall length min/max	1.48/1.86m	1.48/1.86m	1.67/2.05m
Breast/breeching bar height	1.11/1.32m	1.11/1.32m	1.11/1.32m

	HB403	HB403 BASIC	HB506	HB506 BASIC	HB511	HB511 BASIC
Features						
Front Ramp*	STD	N/A	STD	N/A	STD	N/A
Ramp / Van Style Doors	N/A	N/A	OPTION	OPTION	OPTION	OPTION
Rear Top Doors	STD	OPTION	STD	OPTION	STD	OPTION
Locking Grooms Door	STD	STD	STD	STD	STD	STD
Prop Stands	OPTION	OPTION	OPTION	OPTION	OPTION	OPTION
Roof Ventilator	STD	STD	STD	STD	STD	STD
Centre Partition	N/A	N/A	STD	STD	STD	STD
Head Partition	N/A	N/A	OPTION	OPTION	OPTION	OPTION
Full Width Breast and Breeching Bars	STD	STD	OPTION	OPTION	OPTION	OPTION
Fixed Window - Front	N/A	N/A	STD	STD	STD	STD
Fixed Windows - Side (Pair per trailer)	STD	STD	STD	STD	STD	STD
Sliding Windows - Side (Pair per trailer)	OPTION	OPTION	OPTION	OPTION	OPTION	OPTION
Side Window Protection Bars (Pair per trailer)	OPTION	OPTION	OPTION	OPTION	OPTION	OPTION
Alloy Wheels (Four per trailer)	OPTION	OPTION	OPTION	OPTION	OPTION	OPTION
Locking Wheel Bolts (For Alloy Wheels)	OPTION	OPTION	OPTION	OPTION	OPTION	OPTION
Wheel Trims (Four per trailer)	OPTION	OPTION	OPTION	OPTION	OPTION	OPTION
Wheel Chocks (Pair)	OPTION	OPTION	OPTION	OPTION	OPTION	OPTION
Mudflaps (Pair)	OPTION	OPTION	OPTION	OPTION	OPTION	OPTION
Spare Wheel and Cover	STD	STD	STD	STD	STD	STD
Lockable Spare Wheel Carrier	OPTION	OPTION	OPTION	OPTION	OPTION	OPTION
Wheeled Tack Pack	N/A	N/A	OPTION	OPTION	OPTION	OPTION
Door Mounted Tack Pack	OPTION	OPTION	OPTION	OPTION	OPTION	OPTION
Aluminium Floor	STD	STD	STD	STD	STD	STD
Removable Rubber Floor Matting	STD	STD	STD	STD	STD	STD
Internal Light	STD	STD	STD	STD	STD	STD
Horse Graphics	OPTION	OPTION	OPTION	OPTION	OPTION	OPTION
Stowage Net	OPTION	OPTION	OPTION	OPTION	OPTION	OPTION
Vanity Mirror	STD	STD	STD	STD	STD	STD
High Level Rear Brake Light	OPTION	OPTION	OPTION	OPTION	OPTION	OPTION
Datatag	STD	STD	STD	STD	STD	STD
Horse & Rider First Aid Kit	OPTION	OPTION	OPTION	OPTION	OPTION	OPTION
Trailer Camera (supplied loose, requires fitting)	OPTION	OPTION	OPTION	OPTION	OPTION	OPTION
Trailer Cover (Blue or Green)	OPTION	OPTION	OPTION	OPTION	OPTION	OPTION
Exterior Colours						
Red	✓	✓	✓	✓	✓	✓
Blue	✓	✓	✓	✓	✓	✓
Black	✓	✓	✓	✓	✓	✓
Silver	✓	✓	✓	✓	✓	✓
Graphite Grey	✓	✓	✓	✓	✓	✓
Roof Colour						
Silver	STD	STD	STD	STD	STD	STD
Interior Padding						
Cream	STD	STD	STD	STD	STD	STD

*Unless specified at the time of order, a right hand ramp will be fitted

SECURITY

THE IFOR WILLIAMS COMMITMENT TO TRAILER SECURITY

Each trailer is fitted with an ID plate which has a unique serial number etched on it. Additionally, the drawbar has a different unique number cut through it, which is virtually impossible to alter without noticeably affecting the appearance of the numbers and galvanized finish.

TER - THE NATIONAL PLANT AND EQUIPMENT REGISTER

When you register your new trailer it is automatically registered with TER (The National Plant and Equipment Register). Their mission is to combat plant theft and fraud in the UK and Europe. By registering ownership, both technical and marking details can be made available to international police forces through TER. All Ifor Williams Trailers include free registration to TER once your trailer is registered by your distributor. For further information on TER please see their web site at www.ter-europe.org

DATATAG

Datatag is Europe's leading electronic tagging system and was originally developed to combat theft in the UK motorcycle industry. Datatag transponders (tags) are miniature transmitters. These are hidden deep within the trailer during manufacture, and transmit a unique code that can only be read with special scanning guns. These are issued to Police and HM Customs free of charge. On recovery of a stolen trailer the identity of the trailer can be verified and the rightful owner contacted.

For further information on Datatag please visit their web site at www.datatag.co.uk

Datatags are fitted as standard to all Ifor Williams Horsebox trailers for extra security and peace of mind.

MAINTENANCE

We recommend that your trailer is serviced by a recognised trailer mechanic to ensure it is always kept in best possible condition. All Ifor Williams Trailers distributors provide this service and can advise you on how regularly your trailer will need servicing.

Always clean your trailer outside and in after use, paying particular attention to the outside during winter months, as salt on the road will corrode the galvanized steel.



IFOR WILLIAMS TRAILERS LTD

Cynwyd, Corwen, Denbighshire LL21 0LB

Telephone +44 (0)1490 412527

sales@iwt.co.uk

www.iwt.co.uk

Distributed Worldwide.

Product design, descriptions, colours, specifications are correct at the time of going to press. We constantly strive to improve our products and from time to time this may result in changes to our range or to individual models. Please check that design, description, colours and specifications described in this brochure are still valid at the time of placing an order.

Our distributors have extensive product knowledge and will be pleased to offer assistance in the selection of your horsebox.

© Ifor Williams Trailers Ltd 2008. All rights reserved.

No part of this publication may be reproduced in any form or by any means, without the written permission of Ifor Williams Trailers Ltd.

Design by Ikon Design Ltd. Photography by Red Photography Ltd.
Thanks to Land Rover, Conwy Land Rover and Harratts Mitsubishi.

